

EC-Declaration of conformity as defined by machinery directive 89/392/EEC, Annex II A

Herewith we declare that the below mentioned equipment in it's conception and design and in the execution was manufactured by us in conformity with the provisions of the EC directive. Any modification to the equipment made without our consent will render this declaration invalid.

Description: HORNET 40

Type: electric pump

Year of construction: see equipment

Applied EC-directives: EC- Low voltage guidelines (73/23/EWG)
EC-directive electromagnetic compability (89/336/EWG) version 93/31/EEC

Applied harmonized standards: EN 60335-1, EN 60335-2

Date / signature 25.07.2001 
Dipl.-Ing. Klaus -R. Jacobsen
Chief-engineer

11/2000 Technical subjects can be changed. Copyright by Horn GmbH & Co., KG.



Operating manual

HORNET



<i>Model</i>	<i>W 40</i>	<i>Standard</i>
	<i>W 40</i>	<i>Automatic</i>
	<i>G 40/12</i>	<i>Standard</i>
	<i>G 40/12</i>	<i>Automatic</i>
	<i>G 40/24</i>	<i>Standard</i>
	<i>G 40/24</i>	<i>Automatic</i>



- 1. Safety precautions**
 - 1.1 Working safety instructions
 - 1.2 Requirements to operation site
- 2. General information**
 - 2.1 Manufacturer
 - 2.2 Range of use
 - 2.3 Description
 - 2.4 Technical data
- 3. Assembly instructions**
- 4. Operation**
 - 4.1 Start up
 - 4.2 Normal operation
 - 4.3 Emergency operation
 - 4.4 Automatic nozzle
- 5. Disassembly**
- 6. Maintenance**
- 7. Repair/Service**

Before using this device it is absolutely necessary to read the operating manual. In case of mal functions and damages of the device caused by insufficient knowledge of the operating manual, the warranty claim will be void.

1. Safety Precautions

Definition of symbols and indications

Working safety symbol



This symbol is found at all safety instructions in this operating manual by which, in case of non-observance, a danger of life and limb of individuals may occur. Please follow these instructions and be especially careful in such situations. Pass on the safety instructions to other users. Apart from the instructions in this operating manual, general safety and accident preventive measures must be respected.

Caution sign

Caution !

The "Caution" sign occurs in this operating manual in places where special attention should be given, thus making it possible to observe existing regulations, laws, etc and following a correct operating process and avoid damage to the product and/or parts of it.

1.1 Working Safety instructions

The electric pump has been designed and built in accordance with the relevant basic safety and health requirements of existing EC-directives. However, dangers may result if the product is used for other purposes than described. Any person dealing with assembly, operation and maintenance of the electric pump must have read and understood the complete operating manual.



The electric pump may only be used for delivery of radiator liquids, Diesel and fuel oil of flash point above +55 °C.

Any other use as well as any modifications to the product have to be considered as improper use. The manufacturer may not be held responsible for any damages resulting from such, the risk lies in that case solely with the user.



Motor and switch are not explosion-proof. Operation with fuels of flash point below +55 °C may cause explosions.



The electric pump is not allowed to be used in explosion danger areas.

A proper use of the product also implies the observance of the conditions specified by the manufacturer regarding assembly, set-up, operation and maintenance.

For operation of the electric pump the local safety and accident preventive measures are binding in any case.

1.2 Requirements to operating site

As radiator liquids, fuel and Diesel oils are water-polluting liquids, the regulations regarding protection of ground water and environment in the country and the regulations of installing must be observed.

4.4 Automatic nozzle 2005 (optional)

- The nozzle A 2005 is an according to § 12VbF certificated, self closing nozzle. It has been tested and approved by the PTB under No. III B/S 2299. This certificate can be sent to you if requested.
- An automatic disconnection follows when the tank is full, the nozzle is held in vertical position or when the nozzle (13) falls to the ground with a fixed nozzle lever.
- The nozzle (13) can be fixed during filling of tank by using the holder fixture.
- The spring surrounding the outlet (16) secures a safe adjustment of the nozzle (12) in a tank filler inlet

Caution !

The automatic disconnection of the nozzle does only works when the outlet and the feeler jet, (17) which is situated in the outlet, has not been contaminated and the flow volume is not less than 12 l/min.

5. Disassembly

- In case the pump has to be dismantled from barrel or container
 1. Pull plug out of socket.
 2. Unscrew pump with priming pump from drum-, resp. container-thread.
 3. Take out pump slowly of container (liquid flows entirely out of suction pipe) and place it in an oil-proof basin.
 4. Release discharge hose (6) at pressure connection (9) and let liquid flow out into oil-proof basin.

6. Maintenance

- The pump basically does not need any maintenance.
- Due to existing regulations, however, pump housing, discharge hose and suction nozzle must regularly be checked for damage.
- The discharge hose can easily be replaced by releasing the hose clamps (8) (See also chapter 3 "Assembly Instructions").

7. Repair/Service

- The pump has been designed with the purpose of being able to operate with least possible maintenance. This is obtained by operating the pump according to this operating manual. Should you, however, after all need service, we kindly ask you to contact the Horn-Service department.

4. Operation

4.1 Start up

For the initial operating the pump has to be filled up via repeated pumping with the hand lever (15) of the AZV 16 (23).

Caution !

Due to the legal requirements of an anti-siphon safety feature the head of liquid can drop after a longer non-working time. In this case a renewed pumping might be necessary.

Dry running must be avoided as it may result in destruction of the shaft seal.

Caution !

The electric pump may only be used under observance.

After the filling procedure the nozzle has to be hung up in the pump cap.

The following process must strictly be observed in the order described!

1. Put nozzle into a tank, the backflow of the canister or into a collecting basin. Open nozzle at the nozzle lever.
2. Fill up pump by actuating the nozzle lever (15) until liquid comes forth out of the nozzle.
3. Switch on pump and press down nozzle lever.

Caution !

In order to avoid an exceeding of the admissible temperature, the electric pump should not deliver more than 5 minutes against a closed nozzle.

4.2 Normal operation

Caution !

Avoid dry-running.

A damaged hose may cause spillages.

The hose (6) may not be left lying on the ground in order to avoid damages to the hose.

Normal operation of type with nozzle ZP 19

- a) Switch on electric pump.
- b) Hold nozzle into filling container and/or put nozzle into vehicle tank and press nozzle lever according to quantity required.
- c) Switch off electric pump and put nozzle back onto the tank.

Normal operation of type with automatic nozzle A 2005

- a) Switch on electric pump.
- b) Hold automatic nozzle (12) into filling container and/or put nozzle into vehicle tank and press nozzle lever (13) according to quantity required or lock it with clamp (22). Automatic nozzle A 2005 switches off automatically when the tank is full (Q min = 12 l/min. Do you wish to stop the filling, release nozzle (13) and/or pull up the nozzle lever briefly and then release it.
- c) Switch off electric pump and put nozzle back onto the tank.

4.3 Emergency operation

In case of power failure it is possible to pump small quantities by actuating the lever (15) thus holding open the automatic nozzle and/or the nozzle.

2. General information

2.1 Manufacturer:

Horn GmbH & Co. KG, D-Flensburg

Types:

HORNET W40, (230 V ~), Hornet G 40/12 (12V), Hornet G 40/24 (24 V)

Model HORNET 40 Standard

HORNET W40 Automatic (230 V ~), Hornet G 40/12 Automatic (12V), Hornet G 40/24 Automatic (24 V)

Model HORNET 40 Automatic

2.2 Field of application



The electric pump can only be used for delivery of radiator liquids, fuel and Diesel oil of flash point above +55 °C.

Caution!

The temperature of the flow liquid is not allowed to fall below or exceed -10°C to +35°C.

2.3 Description

- The electric pump is an electrically operated delivery pump for radiator liquids, fuel and Diesel oil of flash point above +55 °C (type 230 V alternating current, 12 V or 24 V direct current).
- The pump is equipped with an self closing nozzle, according to VbF, § 12, or with a nozzle ZP19.
- To avoid environmental damage the pump has been equipped with an anti-siphon safety feature.
- The integrated priming pump means that the pump is always and quickly ready for use. When pu mp is operated for the first time, it must be filled by using the priming pump. The priming pump allows additionally emergency operation for delivery of smallest rates of liquid in case of power failure.
- The automatic self closing nozzle A2005 closes perfectly, when the tank to be filled is full, when the nozzle is held in a vertical position or when the nozzle falls to the ground with a fixed control lever.
- The pump casing is made of high-quality, impact resistant plastic.
- The Hornet 40 is delivered including hose set and self-closing and/or simple, not automatic nozzle.
- Alternatively a non-calibrated flow meter can be installed.

Caution!

Dry operation can cause damage of the shaft seal !

2.4 Technical data

Noise level: 70 db (A) Max. head of suction: 2 m
 Medium temperature: -10° C bis +35° C Max. length of nozzle hose: 6 m
 Year of construction: . Please see name plate suction hose: 1600 mm
 Drum- thread : M64x4 and G2" Protective system: IP 44
 Cable: 2 m

Type HORNET	W40 Standard	W40 Automatic	G40/24 Standard	G40/24 Automatic	G40/12 Standard	G40/12 Automatic
Voltage	230V 50Hz	230V 50Hz	24 V–	24 V–	12 V–	12 V–
currency	1,2 A	1,2 A	7,5 A	7,5 A	12,5 A	12,5 A
Input - power	250 W	250 W	180 W	180 W	150 W	150 W
Capacity	approx 38 l/min	approx 32 l/min	approx 34 l/min	approx 27 l/min	approx 31 l/min	approx 24 l/min
Vertical rise	max. 13 m	max. 13 m	max. 9 m	max. 9 m	max. 8 m	max. 8 m
Weight	3,6 kg	4,5 kg	3,2 kg	4,5 kg	3,2 kg	4,5 kg

* Values at: suction depth 1600 mm, delivery head 0, delivery hose DN19.

3. Assembly instructions

Fit suction filter (1) to suction pipe (2) and secure by means of light hose clamp (3). Slip transparent suction hose (4) approx. 30 mm on the suction pipe (2). Cut the delivery hose to required length and slide it on to the suction pipe socket (5) of the priming pump (14). Tighten both hose clamps (8) on the hose (6). Slip hose on pressure connection (9) of the pump. Slip angular wire end of anti-knirk spring under the hose clamp. Tighten hose clamp (8). Fit nozzle ZP19 to other end of pressure hose (23) using the hose clamp.

Caution !

Nozzle hose must have a resistance of > 10¹¹ Ohm in order to avoid a static boost load.

The Hornet 40 Automatic is designed with an automatic nozzle valve A2005 instead of the nozzle ZP19. For that purpose fit supplied hose union (21) with clamp (8). Plug thread (21) on nozzle and tighten.

Tight pump into opening of tank, thus considering that the pump can only be placed and operated in a **vertical** position.

By twisting the motor casing (11) the pump outlet can be put into the wanted position.

Connect power supply.

For type Hornet G40 a direct currency socket is required according to DIN 72591 C or D.

The circuit cross section of the plug supply line at direct currency operation should amount to 2,5 qmm thus avoiding large voltage drops.

Model HORNET40 Standard

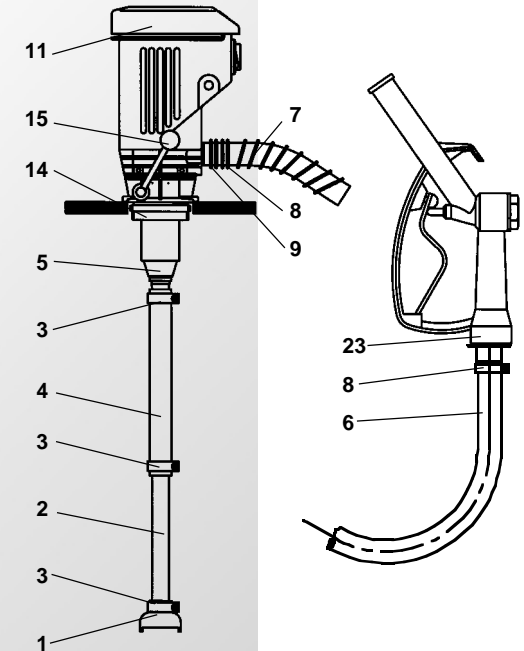

Model HORNET40 Automatic

